

DATA SHEET

MODULETEK: SFP-OC48-LR2-x-E10

OC-48 LR-2/STM L-16.2 SFP (Small Form Pluggable) Transceiver with Digital Diagnostics

Overview

ModuleTek's SFP-OC48-LR2-x-E10 OC-48/STM-16 SFP optical transceivers are designed to comply with ATM/SONET/SDH standards at OC-48 LR-2/STM L-16.2 (2.488Gb/s) data rate. The SFP-OC48-LR2-x-E10 SFP optical transceivers with digital diagnostics monitoring functionality provide a quick and reliable interface for OC-48/STM-16 single mode applications. The digital diagnostics functions are available via a 2-wire serial bus. In addition, they comply with the Small Form Factor Pluggable Multi-Source Agreement (MSA).

Product Features

- Up to 2.488 Gb/s bi-directional data links
- Compliant with IEEE 802.3z Gigabit Ethernet standard
- Compliant with ANSI-T1.646, ATM and SONET and SDH for OC-48/STM-16 (2.488Gb/s)
- Compliant with SFP MSA
- Cooled 1550nm DFB laser transmitter
- Hot-pluggable SFP footprint
- Receiver with APD
- Duplex LC connector
- Built-in digital diagnostic functions
- Up to 80km on SMF
- Single power supply 3.3V
- Power consumption <1.5W
- RoHS Compliant
- Class 1 laser product complies with EN 60825-1
- Operating temperature range (Case Temperature) :
Commercial Level : 0°C to 70°C
Industrial Level : -40°C to 85°C

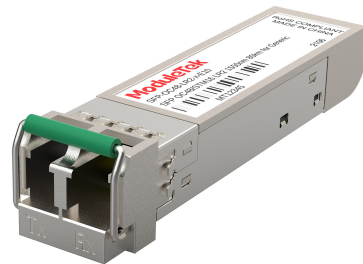

Applications

- SONET OC48 LR-2/SDH STM L-16.2
- Compatible with CIENA

Ordering Information

Part Number	Product ID	Description	Color on Clasp
SFP-OC48-LR2-C-E10	M420203	OC48 LR-2/STM L-16.2 SFP LC Connectors 1550nm Single Mode 80km, with DOM function	green
SFP-OC48-LR2-I-E10	M420204	OC48 LR-2/STM L-16.2 SFP LC Connectors 1550nm Single Mode 80km, with DOM function	green
For More Information: ModuleTek Limited Web: www.moduletek.com Email: sales@moduletek.com			

General Specifications

Parameter	Symbol	Min	Typ	Max	Unit	Remarks
Data Rate	DR			2.488	Gb/s	
Bit Error Rate	BER			10^{-12}		
Operating Temperature	T _C	0		70	°C	1
		-40		85	°C	1
Storage Temperature	T _{STO}	-40		85	°C	2
Supply Current	I _{CC}		200	300	mA	3
Input Voltage	V _{CC}	3.14	3.3	3.46	V	
Maximum Voltage	V _{MAX}	-0.5		4.5	V	3

Notes:

1. Case temperature
2. Ambient temperature
3. For electrical power interface

Transmission distance

Data Rate	Optical Fiber type	Distance range (km)	Remark
2.488Gb/s	9/125um Singel mode fiber	80	

Optical – Characteristics – Transmitter

$V_{CC}=3.14V$ to $3.46V$, T_C

Parameter	Symbol	Min	Typ	Max	Unit	Remarks
Output Optical Power	P_{TX}	-2		3	dBm	1
Optical Center Wavelength	λ_C	1480		1580	nm	
Extinction Ratio	ER	9			dB	
Spectral Width (-20dB)	$\Delta\lambda$			1	nm	
Side Mode Suppression Ratio	SMSR	30			dB	
Optical Rise/Fall Time (20%-80%)	t_r / t_f			180	ps	

Optical – Characteristics – Receiver

$V_{CC}=3.14V$ to $3.46V$, T_C

Parameter	Symbol	Min	Typ	Max	Unit	Remarks
Receiver Overload	P_{OL}	-9			dBm	
Optical Center Wavelength	λ_C	1260		1600	nm	
Receiver Sensitivity	R_{X_SEN}			-28	dBm	
LOS Assert	LOS_A	-40			dBm	
LOS De-Assert	LOS_D			-29	dBm	
LOS Hysteresis	LOS_H	0.5			dB	

Electrical – Characteristics – Transmitter

$V_{CC}=3.14V$ to $3.46V$, T_C

Parameter	Symbol	Min	Typ	Max	Unit	Remarks
Input differential impedance	R_{IN}		100		Ω	
Single ended data input swing	V_{IN_PP}	250		1200	mV	
Transmit disable voltage	V_D	$V_{CC}-1.3$		V_{CC}	V	
Transmit enable voltage	V_{EN}	V_{EE}		$V_{EE}+0.8$	V	
Transmit disable assert time				10	μs	

Electrical – Characteristics – Receiver

$V_{CC}=3.14V$ to $3.46V$, T_C

Parameter	Symbol	Min	Typ	Max	Unit	Remarks
Single ended data output swing	V_{OUT_PP}	300	400	800	mV	
Data output rise/fall time (20%-80%)	t_r/t_f		100	170	ps	
LOS Fault	V_{LOS_A}	$V_{CC}-0.5$		V_{CC_HOST}	V	
LOS Normal	V_{LOS_D}	V_{EE}		$V_{EE}+0.5$	V	

A0H Device register description

IIC Site	Byte size	Register name	Register description	Value(HEX)
0	1	Identifier	SFP	03
1	1	Extended Identifier	Use the IIC interface	04
2	1	Connector	Use the LC connector	07
3-10	8	Transceiver	Transmitter Code	00 0C 00 00 12 00 01 04
11	1	Encoding	NRZ	03
12	1	BR, Nominal	2.67Gb/s nominal rate	1B
13	1	Rate Identifier	No rate selection	00
14	1	Length(9μm)-km	In single-mode fiber transmission 80km	50
15	1	Length (9μm)-100m	In single-mode fiber transmission 80km	FF
16	1	Length (50μm)-10m	The transmission distance in the multimode fiber	00
17	1	Length (62.5μm)-10m	The transmission distance in the multimode fiber	00
18	1	Length (Copper)	The transmission distance over the copper cable	00
19	1	Reserved	Undefined	00
20-35	16	Trade name	MODULETEK	ASCII Format
36	1	Transceiver	Undefined	00
37-39	3	Vendor OUI	Vendor IEEE company ID	00 00 00
40-55	16	Vendor PN	Vendor's product model	Vendor defined
56-59	4	Vendor Revision Number	Vendor's product version number	Vendor defined
60-61	2	Wavelength	The laser has a wavelength of 1550 nanometers	06 0E
62	1	Reserved	Undefined	00
63	1	CC_BASE	0-62 Check and of bytes	Vendor defined
64-65	2	Transceiver Options	1.Rx_LOS Sigal monitoring 2.Tx_FAULT Sigal monitoring 3.Tx_DIS Sigal monitoring	00 1A
66	1	BR, max	High bit rate margin	00
67	1	BR, min	Low bit rate margin	00
68-83	16	Vendor SN	Vendor serial number	Vendor defined
84-91	8	Date code	The date code	Vendor defined
92	1	Monitoring Type	DOM Information internal calibration The received light power is measured using the average light power	68

93	1	Enhanced Options	1. Emitting light and receiving light alarm and warning monitoring 2. Tx_DIS Signal monitoring and control 3. Rx_LOS Signal monitoring 4. Tx_FAULT Signal monitoring	F0
94	1	Compliance	As defined in SFF-8472 in version 12.0	08
95	1	CC_EXT	64-94 Check and bytes	Vendor defined
96-127	32	Vendor Specific	Vendor custom areas	Vendor defined
128-255	128	Vendor Specific	Vendor custom areas	Vendor defined

Digital Diagnostic Functions

SFP-OC48-LR2-x-E10 supports the 2-wire serial communication protocol as defined in SFP MSA . Digital diagnostic information is accessible over the 2-wire interface at the address 0xA2. Digital diagnostics for SFP-OC48-LR2-x-E10 are internally calibrated by default. The internal micro control unit accesses the device operating parameters in real time, such as transceiver temperature, laser bias current, transmitted optical power, received optical power and transceiver supply voltage. The module implements the alarm function of the SFP MSA , alerts the user when a particular operating parameter exceeds the factory-set normal range.

DDM Threshold Information

Parameter		Alarm Threshold		Warning Threshold	
		High Value	Low Value	High Value	Low Value
Temperature (°C)	C	75 (4B 00)	-5 (FB 00)	70 (46 00)	0(00 00)
	I	90 (5A 00)	-45 (D3 00)	85 (55 00)	-40 (D8 00)
Voltage (V)		3.63(8D CC)	2.97 (74 04)	3.46 (87 28)	3.13 (7A 44)
Bias Current (mA)		100 (C3 50)	2 (03 E8)	80 (9C 40)	4 (07 D0)
Tx Power (dBm)		3.79 (5D 87)	-2.97 (13 E8)	3 (4D F0)	-2 (18 A5)
Rx Power (dBm)		-6 (09 D0)	-33.01 (00 05)	-9 (04 EA)	-30 (00 0A)

Parameter	Symbol	Accuracy	Units	Report Range		Unit	Remarks
Internal Calibration							
Temperature	Temp	±3	°C	-40	95	°C	
Voltage	V _{CC}	±0.1	V	2.7	3.9	V	
Bias Current	I _{bias}	±10	%	1	80	mA	
Tx Power	P _{TX}	±3	dB	-10	5	dBm	
Rx Power	P _{RX}	±3	dB	-33	-6	dBm	

Dimensions

Module Weight: 16.5g

Dust Cap Weight: 0.95g

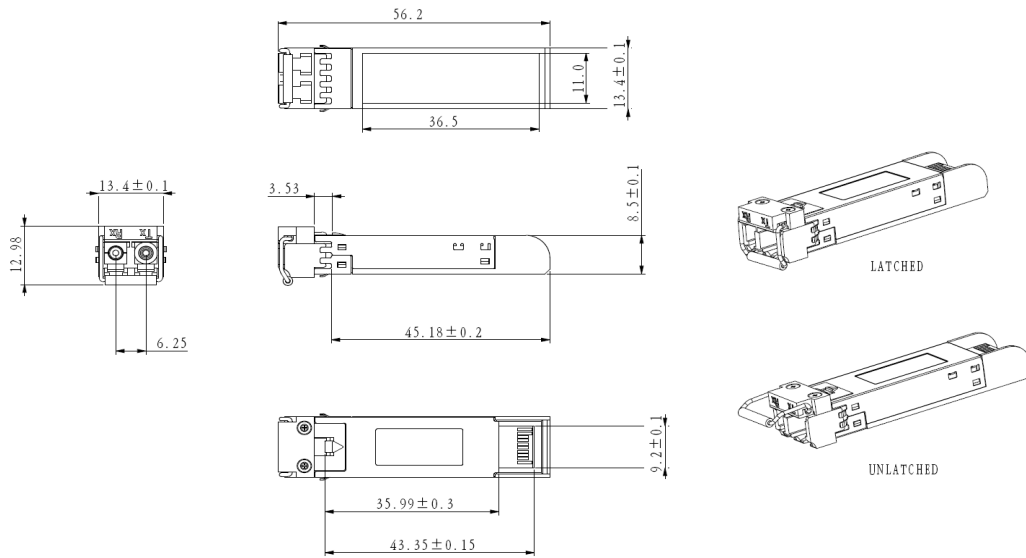

ALL DIMENSIONS ARE ±0.2mm UNLESS OTHERWISE SPECIFIED
UNIT: mm

Electrical Pad Layout

Top of Board

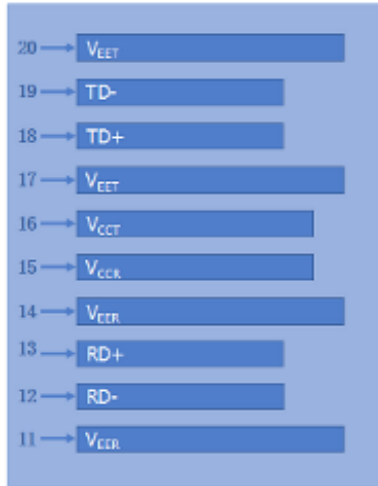

Bottom of Board

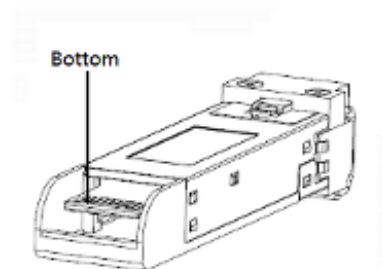
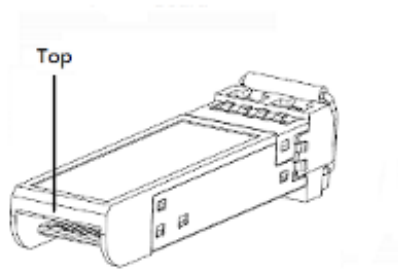
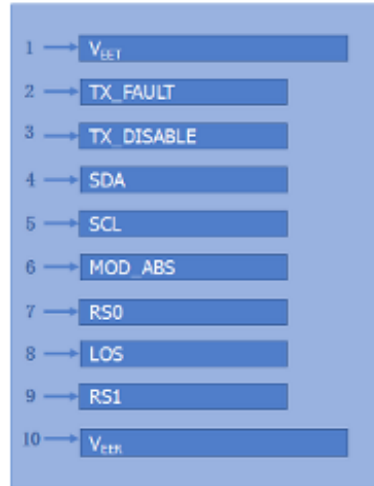

Pin Assignment

PIN #	Symbol	Description	Remarks
1	V _{EET}	Transmitter ground (common with receiver ground)	1
2	TX_FAULT	Transmitter Fault. Not supported	
3	TX_DISABLE	Transmitter Disable. Laser output disabled on high or open	2
4	MOD_DEF(2)	Module Definition 2. Data line for serial ID	3
5	MOD_DEF(1)	Module Definition 1. Clock line for serial ID	3
6	MOD_DEF(0)	Module Definition 0. Grounded within the module	3
7	Rate Select	No connection required	
8	LOS	Loss of Signal indication. Logic 0 indicates normal operation	4
9	V _{EER}	Receiver ground (common with transmitter ground)	1
10	V _{EER}	Receiver ground (common with transmitter ground)	1
11	V _{EER}	Receiver ground (common with transmitter ground)	1
12	RD-	Receiver Inverted DATA out. AC coupled	
13	RD+	Receiver Non-inverted DATA out. AC coupled	
14	V _{EER}	Receiver ground (common with transmitter ground)	1
15	V _{CCR}	Receiver power supply	
16	V _{CCT}	Transmitter power supply	
17	V _{EET}	Transmitter ground (common with receiver ground)	1
18	TD+	Transmitter Non-Inverted DATA in. AC coupled	
19	TD-	Transmitter Inverted DATA in. AC coupled	
20	V _{EET}	Transmitter ground (common with receiver ground)	1

Notes:

1. Circuit ground is isolated from chassis ground
2. Disabled: T_{DIS} > 2V or open, Enabled: T_{DIS} < 0.8V
3. Should Be pulled up with 4.7k – 10k ohm on host board to a voltage between 2V and 3.6V
4. LOS is open collector output

References

1. IEEE standard 802.3. IEEE Standard Department, 2002.
2. Small Form Factor Pluggable (SFP) Transceiver Multi-Source Agreement (MSA), INF-8074i.
3. Bellcore GR-253 and ITU-T G.957 Specifications.