

DATA SHEET

MODULETEK: QSFP-100G-SR4-C-G12

100G QSFP SR4 Short Wavelength (850nm) Transceiver

Overview

QSFP-100G-SR4-C-G12 optical transceivers are based on 100G Ethernet IEEE 802.3 standard and complies with SFF-8636 standard, providing fast and reliable interface for 100G Ethernet. It provides four independent transmit and receive channels, each capable of 25Gbps, with a total bandwidth of 100Gbps, making it a high-performance, low-power, short-haul interconnect solution.

Product Features

- Supports 4-channel 25.78125Gbps bi-directional data links
- Compliant with IEEE 802.3
- Compliant with SFF-8636
- Hot-pluggable QSFP footprint
- 850nm VCSEL array laser transmitter
- Single 1X12 MPO receptacle
- Built-in digital diagnostic functions
- Low power consumption (Operating Power <2.0W)
- Single power supply 3.3V
- RoHS-6 Compliant
- Supports operation without host FEC for lowest latency and minimal host power dissipation
- Maximum link length of 30m on OM3 and 40m on OM4 without host FEC
- Maximum link length of 50m on OM3 and 70m on OM4 with host Clause 74 (Firecode) FEC
- Maximum link length of 70m on OM3 and 100m on OM4 with host Clause 91 (RS) FEC
- Operating temperature range (Case Temperature): Commercial Level: 0°C to 70°C



Applications

- 100GBASE-SR4 100G Ethernet without host FEC
- 100GBASE-SR4 Ethernet with Firecode host FEC
- 100GBASE-SR4 100G Ethernet with RS host FEC
- InfiniBand EDR

Ordering Information

Part Number	Produce ID	Description	Color on Clasp
QSFP-100G-SR4-C-G12	M321809	100G QSFP 850nm MPO receptacle	beige
Notes: 1.Product ID is the abbreviated order number of our company's product standard model			
For More Information Or To Order The Above Products, Please Contact: Email: sales@moduletek.com ModuleTek Web: www.moduletek.com			

General Specifications

Parameter	Symbol	Min	Typ	Max	Unit	Remarks
Operating Temperature	T_C	0		70	°C	1
Storage Temperature	T_{STO}	-40		85	°C	2
Supply Current	I_{CC}			750	mA	3
Input Voltage	V_{CC}	3.15	3.3	3.46	V	
Maximum Voltage	V_{MAX}	-0.5		3.6	V	
Power Dissipation	P			2000	mW	

Notes:

1. Case temperature
2. Ambient temperature
3. For electrical power interface

Link Distances

Parameter	Symbol	Min	Typ	Max	Unit	Remarks
Data Rate (Per Channel)	DR		25.78125		Gbps	
Bit Error Rate (no FEC mode)	BER			1×10^{-12}		1,2
Bit Error Rate (FC-FEC)	BER			1×10^{-8}		1,3
Bit Error Rate (RS-FEC)	BER			5×10^{-5}		1,4
OM3 MMF (Bandwidth 2000MHz*km)	L			30	M	2
OM4 MMF (Bandwidth 4700MHz*km)	L			40	M	2
OM3 MMF (Bandwidth 2000MHz*km)	L			50	M	3
OM4 MMF (Bandwidth 4700MHz*km)	L			70	M	3
OM3 MMF (Bandwidth 2000MHz*km)	L			70	M	4
OM4 MMF (Bandwidth 4700MHz*km)	L			100	M	4

Notes:

1. Measured with data rate at 25.78125Gbps, PRBS $2^{31}-1$
2. This module requires no FEC on the host ports for operation at 25G
3. This module requires FC-FEC on the host ports for operation at 25G
4. This module requires RS-FEC on the host ports for operation at 25G

Optical Characteristics – Transmitter

$V_{CC}=3.15V$ to $3.46V$, $T_C=0^{\circ}C$ to $70^{\circ}C$

Parameter	Symbol	Min	Typ	Max	Unit	Remarks
Tx Optical Power (Per Channel)	P_{TX}	-6		2.4	dBm	1
Optical Center Wavelength	λ_C	840	850	860	nm	
Optical Modulation Amplitude	OMA	-4		3	dBm	
Extinction Ratio	ER	2			dB	
Spectral Width (RMS)	$\Delta\lambda$			0.60	nm	
Transmitter Dispersion Eye Closed	TDEC			3	dB	
Average Launch Power of OFF Transmitter (Per Channel)	P_{OUT_OFF}			-30	dBm	1

Notes:

1. Average optical power

Optical Characteristics – Receiver

$V_{CC}=3.15V$ to $3.46V$, $T_C=0^{\circ}C$ to $70^{\circ}C$

Parameter	Symbol	Min	Typ	Max	Unit	Remarks
Optical Center Wavelength	λ_C	840	850	860	nm	
Receive Sensitivity (Per Channel)	P_{RX}	-10.3		2.4	dBm	1
Optical Return Loss	ORL	12			dB	
LOS Assert	LOS_A	-30			dBm	
LOS De-Assert	LOS_D			-11	dBm	
LOS Hysteresis	LOS_H	0.5			dB	

Notes:

1.Average optical power, using 25.78125 Gbps, PRBS $2^{31}-1$ signal test, BER 5×10^{-5} , without fiber

Electrical Characteristics – Transmitter

$V_{CC}=3.15V$ to $3.46V$, $T_C=0^{\circ}C$ to $70^{\circ}C$

Parameter	Symbol	Min	Typ	Max	Unit	Remarks
Input differential impedance	R_{IN}		100		Ω	
Differential Data Input Swing	V_{IN_PP}	180		1200	mV	
Transmitter Disable Voltage	V_D	2		V_{CC}	V	
Transmitter Enable Voltage	V_{EN}	V_{EE}		$V_{EE}+0.8$	V	

Electrical Characteristics – Receiver

$V_{CC}=3.15V$ to $3.46V$, $T_C=0^{\circ}C$ to $70^{\circ}C$

Parameter	Symbol	Min	Typ	Max	Unit	Remarks
Differential output swing	V_{OUT_PP}	300		850	mV	
Data Output Rise/Fall Time (20%-80%)	t_r/t_f	12			ps	
LOS Assert	V_{LOS_A}	2		V_{CC_HOST}	V	
LOS De-Assert	V_{LOS_D}	V_{EE}		$V_{EE}+0.8$	V	

Digital Diagnostic Function

QSFP-100G-SR4-C-G12 supports the 2-wire serial communication protocol defined in SFF-8636, which provides access to digital diagnostic information through a 2-wire interface. The internal micro-controller unit provides real-time access to module operating parameters such as module temperature, laser bias current, transmit optical power, receive optical power and module supply voltage. The module

implements the SFF-8636's alarm function, which alerts the user when specific operating parameters are out of normal range.

Digital Diagnostic Threshold Range				
Parameter	High Alarm(HEX)	High Warning(HEX)	Low Warning(HEX)	Low Alarm(HEX)
Temperature(°C)	75.00(4B00h)	70.00(4600h)	0.00(0000h)	-5.00(FB00h)
Voltage(V)	3.63(8DCCh)	3.46(8728h)	3.13(7A44h)	2.97(7404h)
Bias Current(mA)	12.00(1770h)	11.50(1676h)	2.00(03E8h)	1.00(01F4h)
Tx Power(dBm)	3.40(5575h)	2.40(43E2h)	-6.00(09D0)	-7.00(07CB)
Rx Power(dBm)	3.40(5575h)	2.40(43E2h)	-10.30(03A5h)	-11.30(02E5h)

A0h Write Protection

Security Level 1 Password (Factory Value)		
Password Entry ADDR	Size	Vaules(HEX)
A0h, 123h-126h	4	00 00 10 11

QSFP-100G-SR4-C-G12 has the function of A0h write-protection, which allows users to enter the security level 1 working state and write the contents of Table 00 and Table 02 of the device address A0h. The method to enter the security level 1 working state is to write the security level 1 password sequentially in the 123h-126h registers of the device address A0h; after entering the security level 1, the user can modify the contents of the 127h Table Selection Register of the device address A0h to write the contents of Table 00 and Table 02. This version module supports users to modify the password of security level 1 by writing a new security level 1 password in the 119h-122h register(Password Change Entry) in the device address A0h; the new security level password ranges from 00000000-7FFFFFFF (hex), and the highest bit of the new security level 1 password must be 0b.

A0h Register Map Low 128 Bytes

Lower Memory Map (A0h)				
IIC ADDR	Size	Name	Description	Initial Vaules(HEX)
0	1	Identifier	QSFP28	11
1	1	Revision Compliance	SFF-8636 Rev 2.10	08

2	1	Status	Bit7-Bit3=0000: Reserved Bit2=0: Upper memory Paged (at least upper page 03h implemented) Bit1: Digital state of the IntL Interrupt output pin Bit0: Data Not Ready	Variable
3	1	Channel Status LOS Flag	Tx/Rx LOS Flag	Variable
4	1	Channel Status TX Adapt EQ Fault/TxFault Flag	Bit7-Bit4: This product does not support this function Bit3-Bit0: TxFAULT Flag	Variable
5	1	Channel Status LOL Flag	Tx/Rx CDR LOL Flag	Variable
6	1	Module Monitor Temperature Alarm/Warning Flag	Bit7-Bit4: Temperature Alarm/Warning Flag Bit3-Bit2: Reserved Bit1: This product does not support this function Bit0: initialization completion flag bit	Variable
7	1	Module Monitor Vcc Alarm/Warning Flag	Vcc Alarm/Warning Flag	Variable
8	1	Vendor Specific	Vendor Specific information	00
9-10	2	Channel Mon RxPower Alarm/Warning Flag	RxPower Alarm/Warning Flag	Variable
11-12	2	Channel Mon TxBias Alarm/Warning Flag	TxBias Alarm/Warning Flag	Variable
13-14	2	Channel Mon TxPower Alarm/Warning Flag	TxPower Alarm/Warning Flag	Variable
15-18	4	Reserved	Reserved channel monitor flags	00 00 00 00
19-21	3	Vendor Specific	Vendor Specific information	00 00 00
22-23	2	Module Monitor Temperature	Temperature diagnosis, unit is 1/256°C	Variable
24-25	2	Reserved	Reserved	00 00
26-27	2	Module Monitor Voltage	Supply Voltage diagnosis, unit is 100uV	Variable
28-29	2	Reserved	Reserved	00 00
30-33	4	Vendor Specific	Vendor Specific information	00 00 00 00

34-35	2	Channel Mon Rx1 Power	Rx1 average receive power diagnosis, unit of 0.1uW	Variable
36-37	2	Channel Mon Rx2 Power	Rx2 average receive power diagnosis, unit of 0.1uW	Variable
38-39	2	Channel Mon Rx3 Power	Rx3 average receive power diagnosis, unit of 0.1uW	Variable
40-41	2	Channel Mon Rx4 Power	Rx4 average receive power diagnosis, unit of 0.1uW	Variable
42-43	2	Channel Mon Tx1 Bias	Tx1 bias current diagnosis, unit of 2uA	Variable
44-45	2	Channel Mon Tx2 Bias	Tx2 bias current diagnosis, unit of 2uA	Variable
46-47	2	Channel Mon Tx3 Bias	Tx3 bias current diagnosis, unit of 2uA	Variable
48-49	2	Channel Mon Tx4 Bias	Tx4 bias current diagnosis, unit of 2uA	Variable
50-51	2	Channel Mon Tx1 Power	Tx1 average receive power diagnosis, unit of 0.1uW	Variable
52-53	2	Channel Mon Tx2 Power	Tx2 average receive power diagnosis, unit of 0.1uW	Variable
54-55	2	Channel Mon Tx3 Power	Tx3 average receive power diagnosis, unit of 0.1uW	Variable
56-57	2	Channel Mon Tx4 Power	Tx4 average receive power diagnosis, unit of 0.1uW	Variable
58-73	16	Reserved	Reserved	00 00 00 00 00 00 00 00 00 00 00 00 00 00 00 00
74-81	8	Vendor Specific	Vendor Specific information	00 00 00 00 00 00 00 00
82-85	4	Reserved	Reserved	00 00 00 00
86	1	Control TxDisable	Bit7-Bit4=0000: Reserved Bit3: Bit of Channel4 Laser disable control Bit2: Bit of Channel3 Laser disable control Bit1: Bit of Channel2 Laser disable control Bit0: Bit of Channel1 Laser disable control	Variable
87	1	Control Rx Rate Select	This product does not support this function, Initize to 00 (hex)	00
88	1	Control Tx Rate Select	This product does not support this function, Initize to 00 (hex)	00
89-92	4	Reserved	Reserved	00 00 00 00
93	1	Control Power	This product does not support this function, Initize to 00 (hex)	00
94-97	4	Reserved	Reserved	00 00 00 00

98	1	Control Tx/Rx CDR	Bit7=1 Channel 4 Tx CDR On Bit6=1 Channel 3 Tx CDR On Bit5=1 Channel 2 Tx CDR On Bit4=1 Channel 1 Tx CDR On Bit3=1 Channel 4 Rx CDR On Bit2=1 Channel 3 Rx CDR On Bit1=1 Channel 2 Rx CDR On Bit0=1 Channel 1 Rx CDR On	FF
99	1	Control LP/TxDis, IntL/LOSL	Bit7-Bit2=000000 Reserved Bit1 LPMoDe/TxDis input signal control Bit0 IntL/LOSL output signal control	Variable
100	1	Mask Tx/Rx LOS	Masking Tx/Rx LOS	Variable
101	1	Mask Tx Adapt EQ Fault/TxFault	Bit7-Bit4: This product does not support this function Bit3-Bit0: Masking TxFault	Variable
102	1	Mask Tx/Rx CDR LOL	Masking Tx/Rx CDR LOL	Variable
103	1	Mask Temperature Alarm/Warning	Masking Temperature Alarm/Warning	Variable
104	1	Mask Vcc Alarm/Warning	Masking Voltage Alarm/Warning	Variable
105-106	2	Vendor Specific	Vendor Specific information	00 00
107	1	Max Power Consumption	Maximum power consumption of module, 2.0W, unit of 0.1W	14
108-109	2	Propagation Delay	This product does not support this function, Initialize to 00 (hex)	00
110	1	Free Side Device Properties	Bit7-Bit4=0000 Power 1.5W or higher Bit3=0 This product does not support this function Bit2-Bit0=000 3.3 V	00
111-112	2	Assigned for use by PCI Express	This product does not support this function, Initialize to 00 (hex)	00 00
113	1	Free Side Device Properties	This product does not support this function, Initialize to 00 (hex)	00
114	1	Use by microQSFP	This product does not support this function, Initialize to 00 (hex)	00
115	1	ModSelL wait time	This product does not support this function, Initialize to 00 (hex)	00
116	1	Secondary Extended Spec Compliance	100GBASE-SR4	02
117	1	Transceiver Sub-type, Fiber Face Type	Bit7-Bit4=0000 Unspecified Bit3-Bit2=00 Reserved Bit1-Bit0=01 Fiber Face Type: UPC	01

118	1	Reserved	Reserved	00
119-122	4	Password Change Entry Area(optional)	Modify security level 1 password entry, power-up default 00000000(hex); readback not supported after writing	00 00 00 00
123-126	4	Password Entry Area (optional)	Security level 1 password entry, power-up default 00000000(hex); readback not supported after writing	00 00 00 00
127	1	Page Select Byte	Table selection, select A0h high 128 byte page	00

A0h Register Map High 128 Bytes

Upper Memory Map Page 00h				
ICC Addr	Size	Name	Description	Initial Value(HEX)
128	1	Identifier	QSFP28	11
129	1	Ext. Identifier	Bit7-Bit6=01: Power Class 2 Module (<2.0W) Bit5=0: Power Class 8 not implemented Bit4=0: No CLEI code Bit3=1: Tx with CDR function Bit2=1: Rx with CDR function Bit1-Bit0=00: Power Classes 1 to 4	4C
130	1	Connector Type	MPO connector	0C
131-138	8	Specification Compliance	100GBASE-SR4 Ethernet	80 00 00 00 00 00 00 00
139	1	Encoding	NRZ	03
140	1	Nominal bit rate	Unit is 100Mbps	FF
141	1	Extended Rate Select Compliance	No rate selection function	00
142	1	Length (SMF)	SMF transmission distance, unit of 1KM	00
143	1	Length (OM3 50 um)	OM3 transmission distance, unit of 2M	00
144	1	Length (OM2 50 um)	OM2 transmission distance, unit of 1M	00
145	1	Length (OM1 62.5 um)	OM1 transmission distance, unit of 1M	00
146	1	Length (OM4 50 um)	OM4 transmission distance, unit of 2M	00

147	1	Device technology	Bit7-Bit4=0000: 850nm VCSEL Bit3=0: No wavelength control Bit2=0: Uncooled transmitter device Bit1=0: Pin detector Bit0=0: Transmitter not tunable	00
148-163	16	Vendor name	MODULETEK	ASCII Format
164	1	Extended Module	Supported InfinBand application	10
165-167	3	Vendor OUI	IEEE Company Identifier for the vendor	00 00 00
168-183	16	Vendor PN	Vendor Part Number	ASCII Format
184-185	2	Vendor rev	Vendor Part Revision Number	Defined by vendor
186-187	2	Wavelength	Wavelength is 850nm , unit of 0.05nm	42 68
188-189	2	Wavelength tolerance	Wavelength tolerance is 40nm , unit of 0.005nm	1F 40
190	1	Max case temp	Max case temp is 70°C , unit of °C	46
191	1	CC_BASE	The check code of Bytes 128-190	Defined by vendor
192	1	Options	100GBASE-SR4	02
193	1	Options	Bit7=0 Reserved Bit6=1 LPMode/TxDis input signal is configurable using byte 99, bit 1 Bit5=1 IntL/RxLOSL output signal is configurable using byte 99, bit 0 Bit4-Bit3=00 This product does not support this function Bit2=1 Tx input equalizers fixed-programmable implemented Bit1=1 Rx output emphasis fixed-programmable implemented Bit0=1 Rx output amplitude fixed-programmable implemented	67
194	1	Options	Bit7=1: Tx CDR On/Off Control implemented Bit6=1: Rx CDR On/Off Control implemented Bit5=1: Tx CDR Loss of Lock (LOL) flag implemented Bit4=1: Rx CDR Loss of Lock (LOL) flag implemented Bit3=1: Rx Squelch Disable implemented Bit2=1: Rx Output Disable capable implemented Bit1=1: Tx Squelch Disable implemented Bit0=1: Tx Squelch implemented	FF

195	1	Options	Bit7=1: Memory Page 02 implemented Bit6=0: Memory Page 01 not implemented Bit5=0: Rate selection function not implemented Bit4=1: Tx-DISABLE implemented Bit3=1: Tx-FAULT signal implemented Bit2=0: Tx Squelch implemented to reducing by OMA Bit1=1: Tx Los of signal implemented Bit0=0: Pages 20-21h not implemented	9A
196-211	16	Vendor SN	Vendor Part Serial Number	Defined by vendor
212-219	8	Date Code	Date	Defined by vendor
220	1	Diagnostic Monitoring Type	Bit7-Bit6=00: Reserved Bit5=1: Temperature monitoring implemented Bit4=1: Supply voltage monitoring implemented Bit3=1: Received power measurements type is average power Bit2=1: Transmitter power measurement supported Bit1-Bit0=00: Reserved	3C
221	1	Enhanced Options	Bit7-Bit5=000: Reserved Bit4=1: The initialization complete flag at Byte 6 bit 0 is implemented Bit3=0: Does not support rate selection Bit2=0: This bit is reserved and reads 0 Bit1=0: This product does not support this function Bit0=1: Software reset is implemented. Use byte 93, bit 7	11
222	1	BR, nominal	Nominal baud rate, units of 250Mbps	68
223	1	CC_EXT	The check code of Byte 192-222	Defined by vendor
224-255	32	Vendor Specific	Vendor Specific information	Defined by vendor
Upper Memory Map Page 02h				
IIC Addr	Size	Name	Description	Initial Value(HEX)
128-255	128	User-writable EEPROM	User defined, readable and writeable under security level 1	User-defined
Upper Memory Map Page 03h				
IIC Addr	Size	Name	Description	Initial Vlan(HEX)

128-129	2	Temp High Alarm	Temperature high alarm	See Table Of Threshold Ranges
130-131	2	Temp Low Alarm	Temperature low alarm	See Table Of Threshold Ranges
132-133	2	Temp High Warning	Temperature high warning	See Table Of Threshold Ranges
134-135	2	Temp Low Warning	Temperature low warning	See Table Of Threshold Ranges
136-143	8	Reserved	Reserved	00 00 00 00 00 00 00 00
144-145	2	Vcc High Alarm	Voltage high alarm	See Table Of Threshold Ranges
146-147	2	Vcc Low Alarm	Voltage low alarm	See Table Of Threshold Ranges
148-149	2	Vcc High Warning	Voltage high warning	See Table Of Threshold Ranges
150-151	2	Vcc Low Warning	Voltage low warning	See Table Of Threshold Ranges
152-159	8	Reserved	Reserved	00 00 00 00 00 00 00 00
160-175	16	Vendor Specific	Vendor Specific information	Defined by vendor
176-177	2	Rx Power High Alarm	RX power high alarm	See Table Of Threshold Ranges
178-179	2	Rx Power Low Alarm	RX power low alarm	See Table Of Threshold Ranges

180-181	2	Rx Power High Warning	RX power high warning	See Table Of Threshold Ranges
182-183	2	Rx Power Low Warning	RX power low warning	See Table Of Threshold Ranges
184-185	2	Tx Bias High Alarm	Tx Bias current high alarm	See Table Of Threshold Ranges
186-187	2	Tx Bias Low Alarm	Tx Bias current low alarm	See Table Of Threshold Ranges
188-189	2	Tx Bias High Warning	Tx Bias current high warning	See Table Of Threshold Ranges
190-191	2	Tx Bias Low Warning	Tx Bias current low warning	See Table Of Threshold Ranges
192-193	2	Tx Power High Alarm	TX power high alarm	See Table Of Threshold Ranges
194-195	2	Tx Power Low Alarm	TX power low alarm	See Table Of Threshold Ranges
196-197	2	Tx Power High Warning	TX power high warning	See Table Of Threshold Ranges
198-199	2	Tx Power Low Warning	TX power low warning	See Table Of Threshold Ranges
200-207	8	Reserved	Reserved	00 00 00 00 00 00 00 00
208-215	8	Reserved	Reserved	00 00 00 00 00 00 00 00
216-223	8	Vendor Specific	Vendor Specific information	Defined by vendor

224	1	Tx EQ , Rx Emphasis Magnitude ID	Bit7-Bit4=1010 Max Tx input equalization supported Bit3-Bit0=0111 Max Rx output emphasis supported	A7
225	1	Rx output amplitude support indicators	Bit7-Bit6=00 Reserved Bit5-Bit4=00 Peak-to-peak amplitude stays constant Bit3-Bit0=1111 Rx output amplitude supported	0F
226	1	Control options advertising	Reserved	00
227	1	Control options advertising	Bit7-Bit6=00 This product does not support this function Bit5-Bit4=00 Reserved Bit3=1 Tx Force Squelch implemented Bit2=0 RxLOSL fast mode is not supported Bit1=1 Complies with timing requirements of SFF-8679 optional TxDis fast mode Bit0=0 Reserved	0A
228	1	Control options advertising	This product does not support this function, Initize to 00 (hex)	00
229	1	Control options advertising	This product does not support this function, Initize to 00 (hex)	00
230	1	Optional Channel Controls	This product does not support this function, Initize to 00 (hex)	00
231	1	Optional Channel Controls	Bit7-Bit4=0000 Reserved Bit3 Tx4 Force Squelch Bit2 Tx3 Force Squelch Bit1 Tx2 Force Squelch Bit0 Tx1 Force Squelch	Variable
232	1	Optional Channel Controls	Reserved	00
233	1	Optional Channel Controls	This product does not support this function, Initize to 00 (hex)	00
234	1	Optional Channel Controls	Bit7-Bit4 Tx1 input equalizer control Bit3-Bit0 Tx2 input equalizer control	Variable
235	1	Optional Channel Controls	Bit7-Bit4 Tx3 input equalizer control Bit3-Bit0 Tx4 input equalizer control	Variable
236	1	Optional Channel Controls	Bit7-Bit4 Rx1 output emphasis control Bit3-Bit0 Rx2 output emphasis control	Variable
237	1	Optional Channel Controls	Bit7-Bit4 Rx3 output emphasis control Bit3-Bit0 Rx4 output emphasis control	Variable
238	1	Optional Channel Controls	Bit7-Bit4: Rx1 output amplitude Bit3-Bit0: Rx2 output amplitude	Variable
239	1	Optional Channel Controls	Bit7-Bit4: Rx3 output amplitude Bit3-Bit0: Rx4 output amplitude	Variable

240	1	Optional Channel Controls	Bit7-Bit4: Rx4-Rx1 squelch enable or disable Bit3-Bit0: Tx4-Tx1 squelch enable or disable	Variable
241	1	Optional Channel Controls	Bit7-Bit4=0000: Rx4-Rx1 output enable Bit3-Bit0=0000: This product does not support this function	00
242-243	2	Channel Monitor Masks	Masking Bit for Rx power Alarm/Warning	Variable
244-245	2	Channel Monitor Masks	Masking Bit for Tx Bias current Alarm/Warning	Variable
246-247	2	Channel Monitor Masks	Masking Bit for Tx power Alarm/Warning	Variable
248-249	2	Channel Monitor Masks	Reserved	00 00
250-251	2	Channel Monitor Masks	Reserved	00 00
252-255	4	Reserved	Reserved	00 00 00 00

Notes:

1.The alarm threshold information can be modified according to the customer's definition, please contact us if you have any modification requirements.

Block-Diagram-of-Transceiver

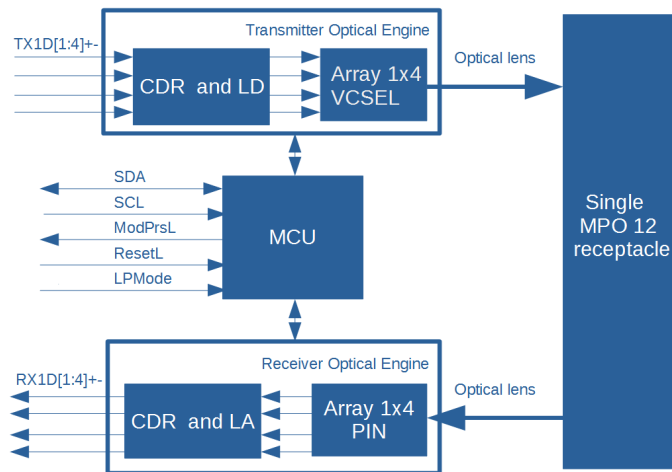

Functions Description

QSFP-100G-SR4-C-G12 module is manufactured by advanced COB (Chip on Board) technology and consists of a microcontroller, an optical engine at the transmitting end and an optical engine at the receiving end. The module has built-in clock and data recovery functions, and the working rate range of the transmitter and receiver of the built-in CDR is 25.5-26Gbps. If you need another version of the

rate range, you can contact us for special customization.

The microcontroller communicates with the host computer via a 2-wire serial communication interface and provides module control, status reporting, and monitoring (DOM) functions in accordance with the SFF-8636 standard.

The transmitter-side optical engine consists of a 4-channel clock data recovery circuit (CDR) and 4-channel laser driver circuit (LD), a 4-channel VCSEL laser. The high-speed differential electrical signal output by the host computer is restored and shaped by the CDR, which is amplified by the laser driver to drive the VCSEL laser to produce the optical signal, and the optical signal is coupled to the optical fiber through the optical lens. The optical engine integrates a photodiode for detection, which is used for output optical power detection.

The receiving optical engine includes a 4-channel photodiode (PIN), a 4-channel signal amplifier (TIA/LA) and a 4-channel receiver clock data recovery circuit (CDR). The optical signal in the optical fiber is coupled to the receiving photodiode (PIN) through an optical lens and converted into photocurrent. After the photocurrent signal is enhanced by the amplifier, it is sent to the CDR circuit and the clock and data signal recovery is completed. Finally, it is output to the host in the form of high-speed differential signal. The microcontroller reads the signal strength (modulation amplitude) received by the photodiode and reports the loss of the received signal if it is lower than the set threshold.

Both the transmitter and receiver have the squelch function. When the transmitter has a signal input, the waveform displayed by the oscilloscope of the transmitter light access is an eye diagram shape, and the waveform displayed by the oscilloscope of the transmitter light access when there is no signal input is a straight line; When the incident light at the receiving end has a signal input, access to the oscilloscope shows that the waveform of the output electrical signal is an eye diagram shape, and when there is no signal input, access to the oscilloscope shows that the waveform of the output electrical signal is a straight line.

Dimensions

Module Weight: 40.35g

Dust Cap Weight: 0.92g

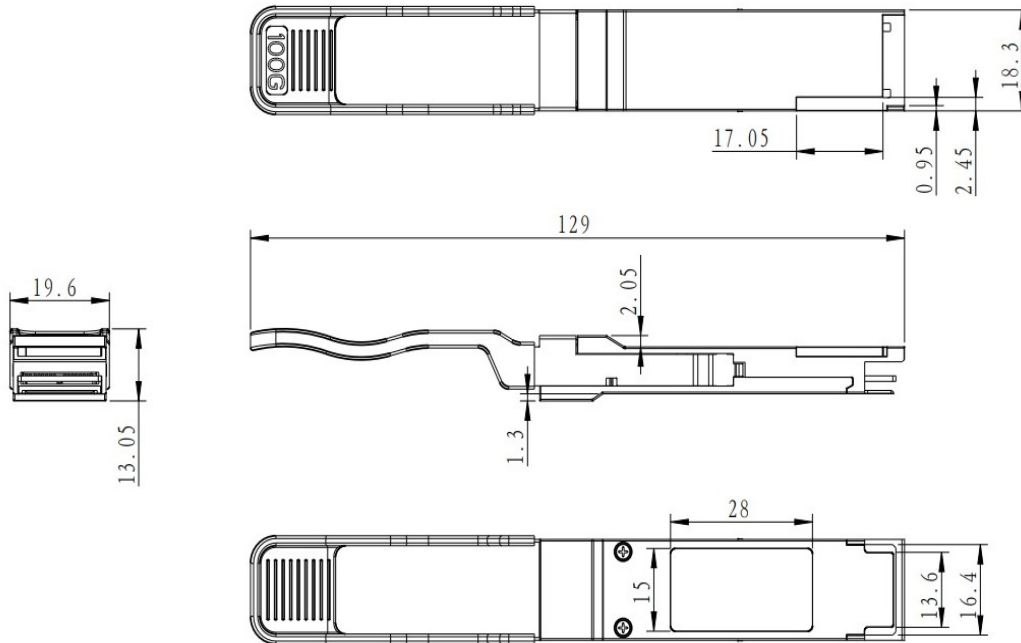

ALL DIMENSIONS ARE ± 0.2 mm UNLESS OTHERWISE SPECIFIED, UNIT: mm

Optical Socket and Channel Orientation for MPO Connectors

Front View Of MPO Optical Port

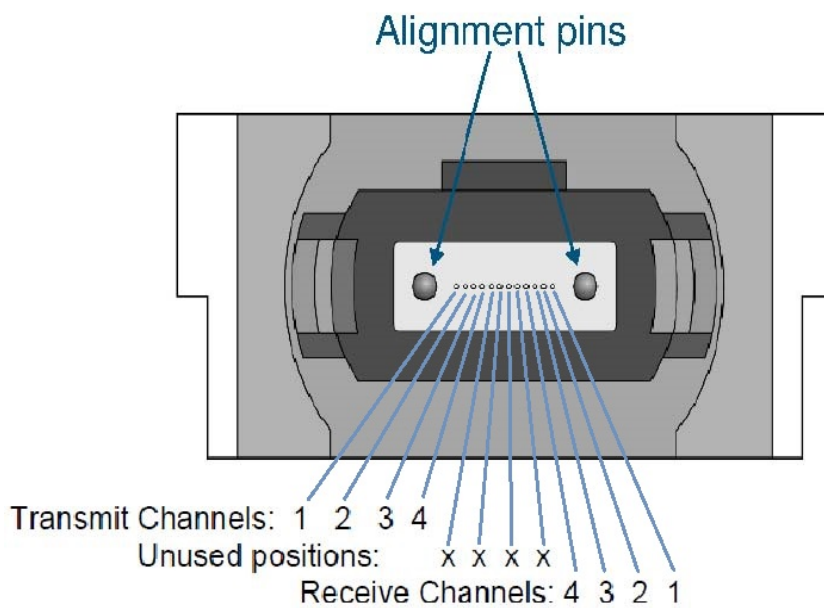

Electrical Pad Layout

Top View Of Board

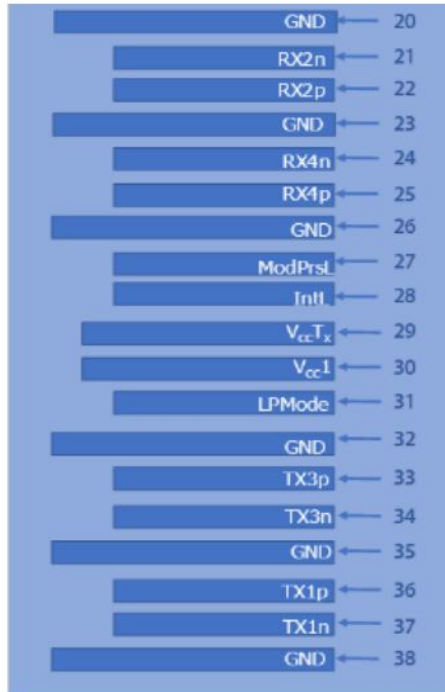

Bottom View Of Board

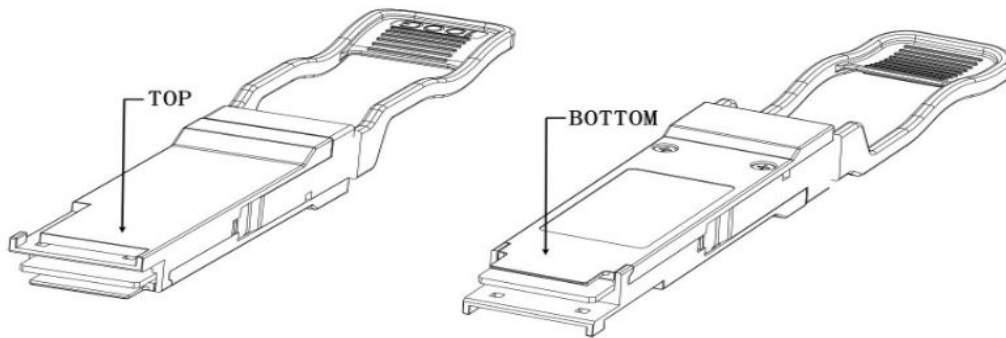
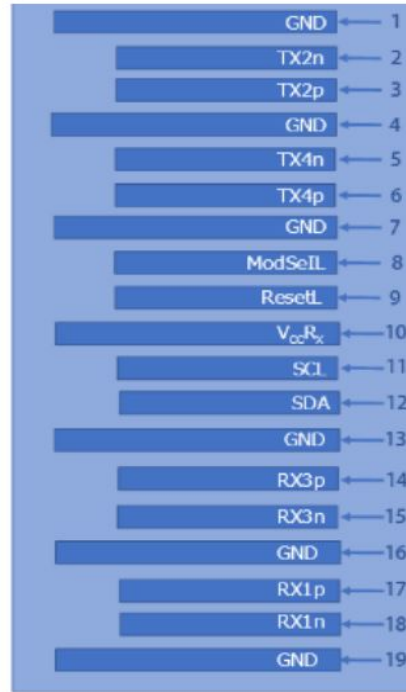

Typical Eye Diagram

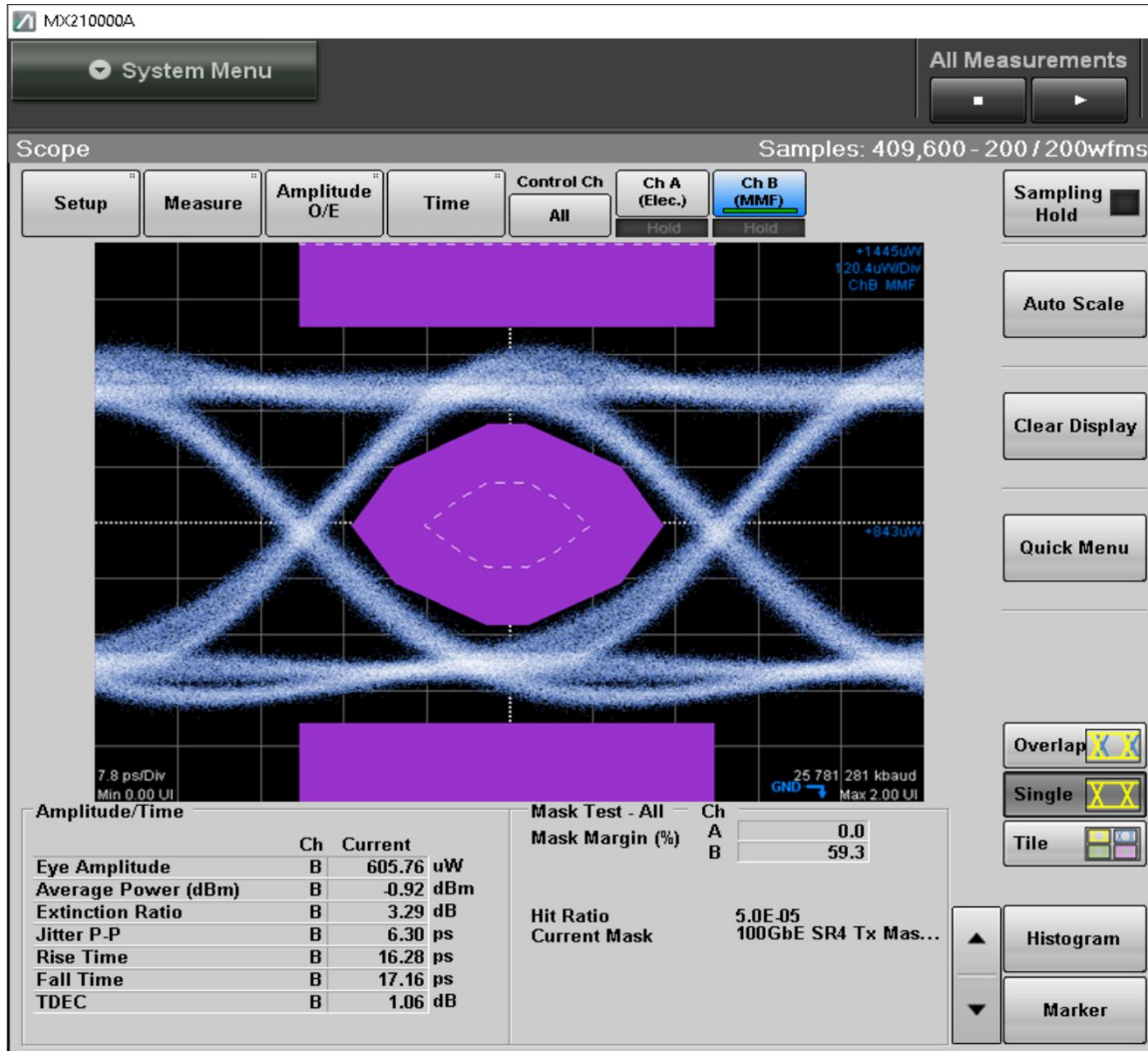

Pin Assignment

PIN #	Symbol	Description	Remarks
1	GND	Ground	5
2	Tx2n	Transmitter Inverted Data Input, LAN2	
3	Tx2p	Transmitter Non-Inverted Data Input, LAN2	
4	GND	Ground	5
5	Tx4n	Transmitter Inverted Data Input, LAN4	
6	Tx4p	Transmitter Non-Inverted Data Input, LAN4	
7	GND	Ground	5
8	ModSelL	Module select pin, the module responds to two-wire serial communication when low level	1
9	ResetL	Module Reset	2
10	V _{cc} R _X	+3.3V Power Supply Receiver	
11	SCL	2-wire serial interface clock	
12	SDA	2-wire serial interface data	
13	GND	Ground	5
14	Rx3p	Receiver Non-Inverted Data Output, LAN3	
15	Rx3n	Receiver Inverted Data Output, LAN3	
16	GND	Ground	5
17	Rx1p	Receiver Non-Inverted Data Output, LAN1	
18	Rx1n	Receiver Inverted Data Output, LAN1	
19	GND	Ground	5
20	GND	Ground	5
21	Rx2n	Receiver Inverted Data Output, LAN2	
22	Rx2p	Receiver Non-Inverted Data Output, LAN2	
23	GND	Ground	5
24	Rx4n	Receiver Inverted Data Output, LAN4	
25	Rx4p	Receiver Non-Inverted Data Output, LAN4	
26	GND	Ground	5
27	ModPrsL	Module insertion indication pin, grounded inside the module	
28	IntL	Interrupt	4
29	V _{cc} T _X	+3.3V Power Supply transmitter	
30	V _{cc} 1	+3.3V Power Supply	
31	LPMODE	Low power mode, pull-up to Vcc inside the module	3
32	GND	Ground	5

33	Tx3p	Transmitter Non-Inverted Data Input, LAN3	
34	Tx3n	Transmitter Inverted Data Input, LAN3	
35	GND	Ground	5
36	Tx1p	Transmitter Non-Inverted Data Input, LAN1	
37	Tx1n	Transmitter Inverted Data Input, LAN1	
38	GND	Ground	5

Notes:

1. ModSelL is the input pin. The module responds to 2-wire serial communication commands when it is held low by the host. ModSelL allows multiple QSFP modules to be used on a single 2-wire interface bus. If ModSelL is High, the module will not respond to any 2-wire interface communication from the host. ModSelL has internal pull-up resistors in the module.
2. The module restart pin, when the low level on the ResetL pin lasts longer than the minimum pulse length, resets the module and restores all user modules to their default state. When performing reset device, the host should ignore all status bits. Until the module reset interrupt is completed, please note that during hot plugging, the module will issue this information to complete the reset interrupt without resetting.
3. When the pin is high, it means that the module is running in low power mode and the transmitter will be turned off; when the pin is low, it means that the module is running in non-low power mode and the module works normally.
4. IntL is the output pin, which is the open collector output and must be pulled up to Vcc on the motherboard. When it is low, it indicates that the module may malfunction. The host uses a 2-wire serial interface to read internal status.
5. Circuit ground is internally isolated from chassis ground.

References

1. IEEE Std 802.3™ 2022.
2. SFF-8636 Specification for Management Interface for 4-lane Modules and Cables Rev 2.11 January 03, 2023.